

# MK233A Overcurrent Relay User's Guide

## A BRIEF OVERVIEW

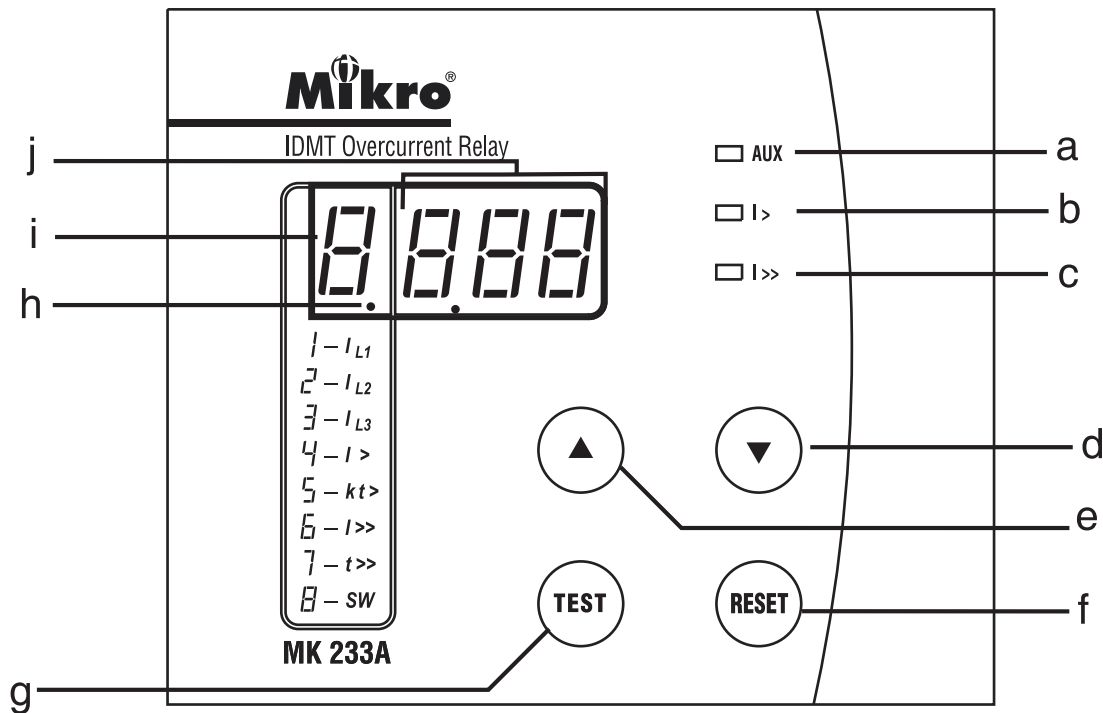

- a - Auxiliary power supply indicator
- b - Low-set start/trip status indicator
- c - High-set start/trip status indicator
- d - Down key
- e - Up key
- f - Reset key
- g - Test key
- h - DP indicator
- i - FUNCTION indicator
- j - DATA indicator

### Symbols

- $I_{L1}$  - L1 current
- $I_{L2}$  - L2 current
- $I_{L3}$  - L3 current
- $I >$  - Low-set
- $kt >$  - Low-set time multiplier/delay time
- $I >>$  - High-set
- $t >>$  - High-set delay time
- SW - Soft switches

## 1. DESCRIPTION

The MK233A is microprocessor based numerical overcurrent relay. It uses fundamental frequency current measurement for excellent harmonic current rejection. The relay consists of independent low-set and high-set elements. The high-set element can be disabled by the user. The time current characteristics of the low set element are definite time or five selectable IDMT curves. The high-set element is a definite time or instantaneous relay. The 4-digit panel display on the MK233A allows the display of the present load current; recorded fault current for last tripping; and all settings of the relay.

## 2. LIGHT INDICATORS

The indicators display the status of the system as follow:

Indicator					Status
Aux	I>	I>>	FUNC	DT	
0	0	0	0	0	No Auxiliary power supply.
1	0	0	X	X	Normal condition, no tripping.
1	1	0	X	X	Low-set overcurrent triggered, time delay countdown started.
1	0	1	X	X	High-set overcurrent triggered, time delay countdown started.
1	B	0	B	B	Low-set tripped, FUNC LED indicates tripping source, DT LEDs show tripped value.
1	0	B	B	B	High-set tripped, FUNC LED indicates tripping source, DT LEDs show tripped value.
1	X	X	B	1	Programming mode.

Table 1: System Status

1 = ON 0 = OFF X= don't care, not blinking  
B = blinking DT = DATA FUNC = FUNCTION

Indicator		
FUNCTION	DP	DATA
1	off	L1 load current.
2	off	L2 load current.
3	off	L3 load current.
1	blink	L1 previous tripped current.
2	blink	L2 previous tripped current.
3	blink	L3 previous tripped current.
4	off	Low-set current setting.
5	off	Time multiplier /delay time setting.
6	off	High-set current setting.
7	off	High-set delay time setting.
8	off	Soft switch setting.

Table 2: FUNCTION Code

Note: Under normal operating condition, The 4-digit display is off. When the RESET key is pressed, the 4-digit display will light up. The display will switch off automatically after 6 minutes if no further key is pressed.

## 3. PUSH-BUTTONS OPERATION

### a) Trip test

Press the "TEST" button to simulate a trip condition.

### b) Trip reset

Press the "RESET" button to reset the relay when tripped.

### c) View setting

When the relay is not under tripped condition, pressing the "RESET" button will scroll through the various functions.

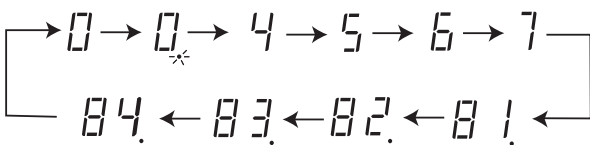

Figure 1: Scroll sequence

### d) Program setting

Only function codes from 4 to 8 can be programmed.

Step 1: Press RESET key until the function digit shows required function.

Step 2: Press the UP and DOWN key simultaneously to enter programming mode. The function digit will blink to indicate the relay is in programming.

Step 3: Use the UP or DOWN key to select the desired value.

Step 4: To save the selected value, press the UP and DOWN key simultaneously again. It will exit the programming mode with the data digits displaying new setting.

To exit programming mode without saving the selected setting, press the RESET key once.

## 4. OUTPUT CONTACTS

The MK233A has two set of output contact:

- (i) CONTACT R1 - linked to trip signal.
- (i) CONTACT R2 - linked to trip or start signal.

The output contact can be programmed to be either auto reset type or manual reset type.

For auto reset type, the contact remain activated until the fault current is removed.

For manual reset type, the contact remain activated even with the removal of fault current.

## 5. SOFT SWITCHES

The MK233A incorporates 4 soft switches for system configuration. When the function digit shows "8", the relay is in soft switch setting mode.

8888



switch number (SW)

SW	SVL	System configuration
1	00	Contact R1 linked to trip signal auto reset type.
	01	Contact R1 linked to trip signal manual reset type.
2	00	Contact R2 linked to trip signal auto reset type.
	01	Contact R2 linked to trip signal manual reset type.
	10	Contact R2 linked to signal auto reset type.
	11	Contact R2 linked to signal manual reset type.
3	00	Low-set normal inverse curve 3/10.
	01	Low-set normal inverse curve 1.3/10.
	02	Low-set long time inverse curve.
	03	Low-set very inverse curve.
	04	Low-set extremely inverse curve.
4	05	Low-set definite time.
	00	High-set disabled.
01	High-set enabled.	

Table 3: Soft switch setting

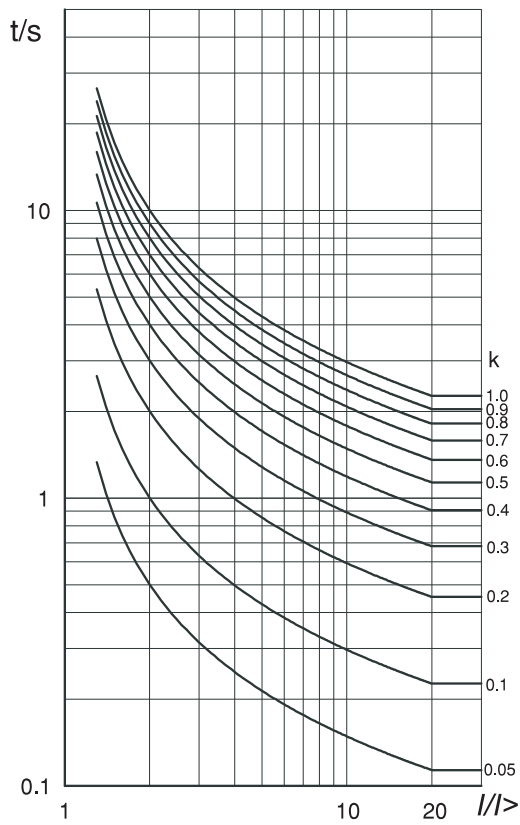

Figure 2: IDMT Normal Inverse Curve 3/10

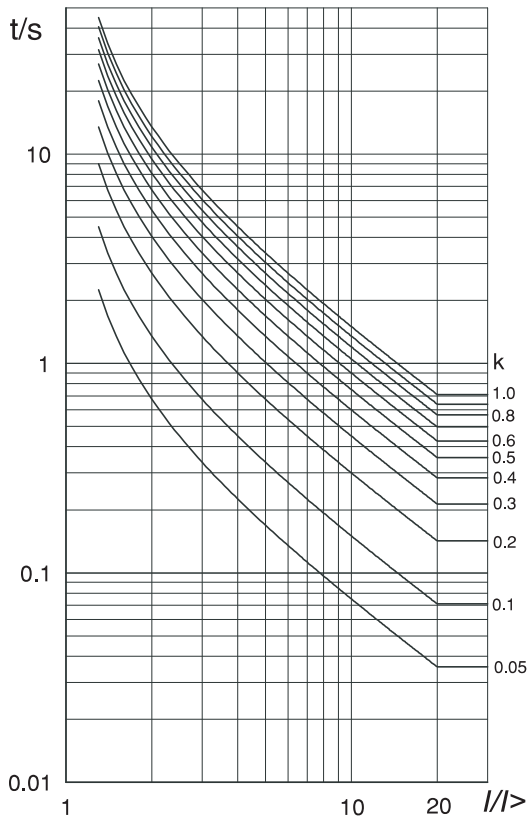

Figure 5: IDMT Very Inverse Curve

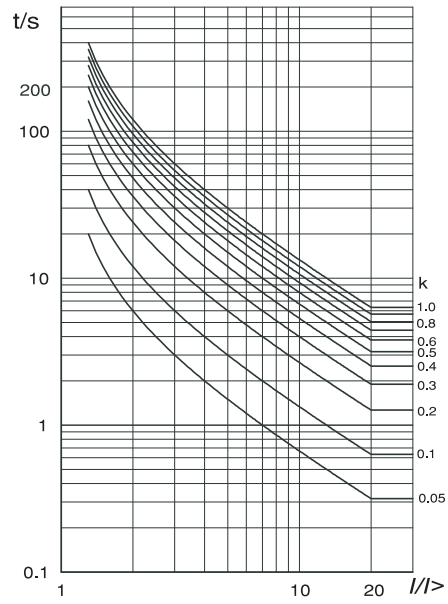

Figure 4: IDMT Long time Inverse Curve

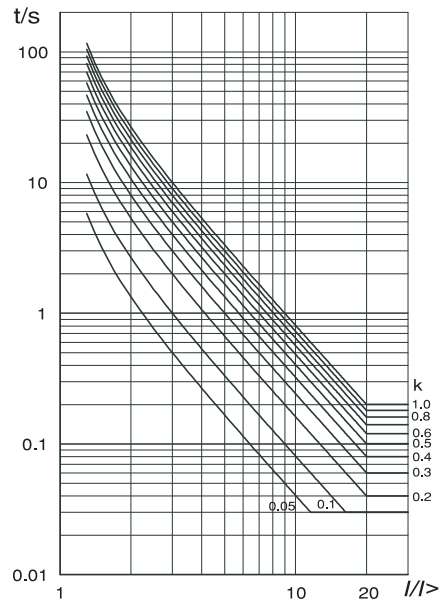

Figure 6: IDMT Extremely Inverse Curve

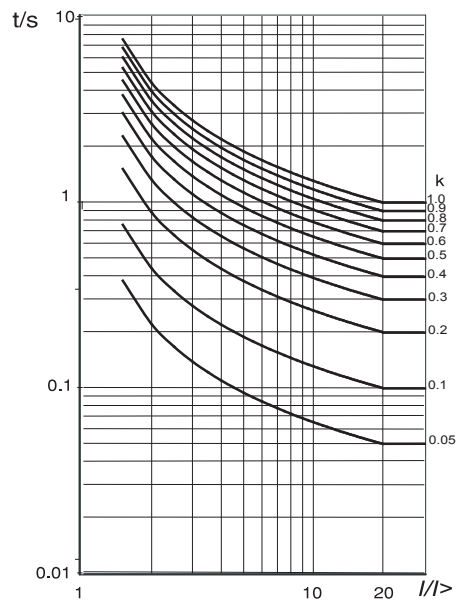

Figure 5: IDMT Normal Inverse Curve 1.3/10

## 6. TECHNICAL DATA

### Ratings

Rated current $I_n$ .....	5 A
Frequency .....	50 Hz or 60 Hz
Burden .....	< 0.3 VA at $I_n$

### Auxiliary Supply

MK233A-240A(6).....	198~265 VAC
MK233A-110A(6).....	94~127 VAC
Supply frequency .....	50 Hz or 60 Hz
VA rating .....	3 VA typical

### Setting Ranges

Low-set setting $I>$ .....	0.5 - 6.00 A (10%-120%)
Time multiplier $kt>$ .....	0.05- 1.00
Low-set definite time $t>$ .....	0.05- 99 sec
High-set setting $I>>$ .....	0.50 - 99.9 A (10%-1998%)
High-set definite time $t>>$ .....	0.05 - 2.5sec

### Outputs

Trip Contact:

Rated voltage .....	250 VAC
Continuous carry .....	5A (cos $\varphi$ = 1.0)
Make and carry for 0.2 s .....	30A

Contact specification

Expected electrical life .....	$10^5$ operations
Expected mechanical life .....	$5 \times 10^6$ operations

### Indicators

Auxiliary supply .....	Green LED indicator
Pick up .....	Red LED indicator
Trip .....	7 segment LED and red LED indicators

### Mechanical

Mounting .....	Panel mounting
Front panel .....	Standard DIN 96x96 mm
Approximate weight .....	0.7 kg

## 7. CONNECTION DIAGRAMS

a) Overcurrent Relay

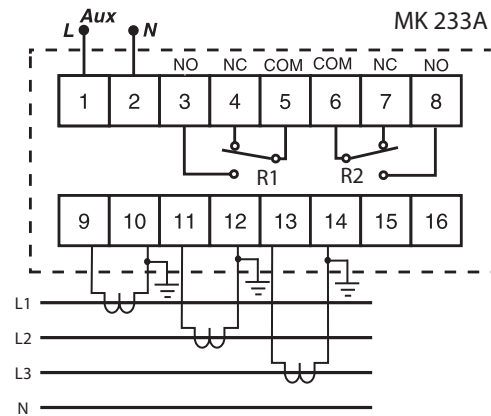

b) Overcurrent Relay and Earth fault relay (3 phase 4 wire system)

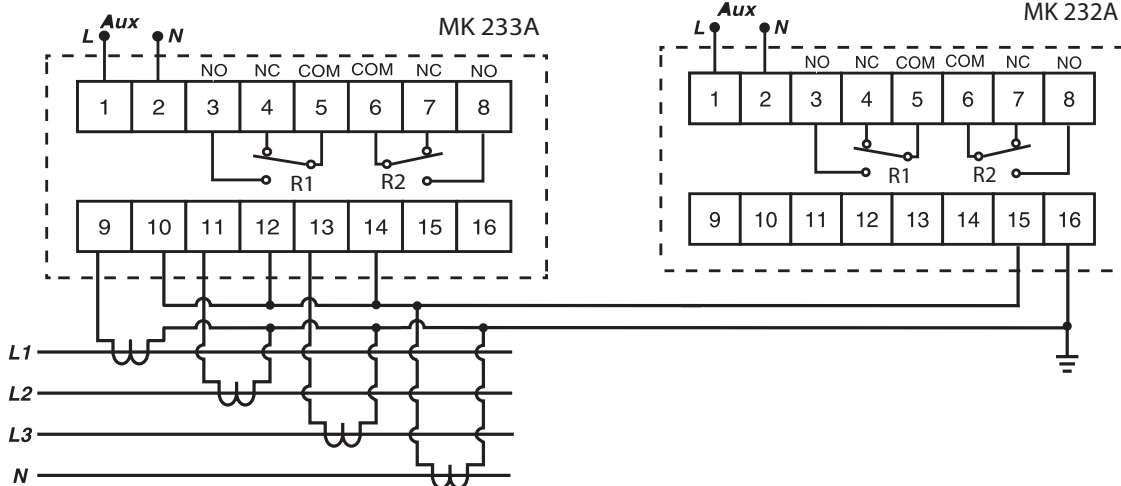

## 8. CASE DIMENSION

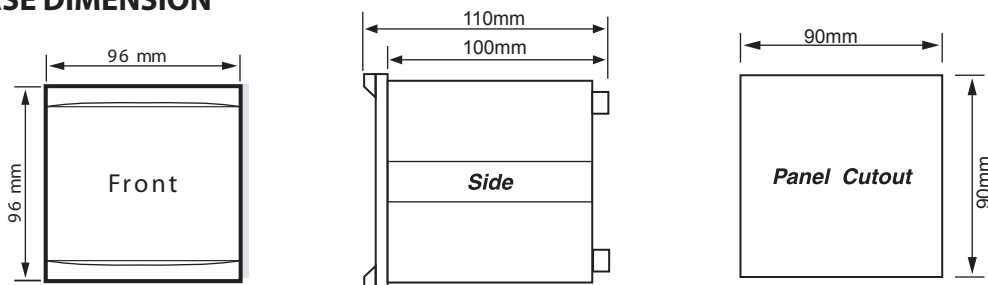

Figure 7: Case Dimension